



US009194148B1

(12) **United States Patent**  
**Koller et al.**

(10) **Patent No.:** **US 9,194,148 B1**  
(45) **Date of Patent:** **Nov. 24, 2015**

(54) **WATER BONDING DEVICE AND METHODS OF USE**

(71) Applicants: **Barrett Koller**, Pueblo, CO (US);  
**Andrew Heggie**, Canon City, CO (US)

(72) Inventors: **Barrett Koller**, Pueblo, CO (US);  
**Andrew Heggie**, Canon City, CO (US)

(\*) Notice: Subject to any disclaimer, the term of this patent is extended or adjusted under 35 U.S.C. 154(b) by 467 days.

(21) Appl. No.: **13/676,004**

(22) Filed: **Nov. 13, 2012**

(51) **Int. Cl.**  
**E04H 4/00** (2006.01)  
**E04H 4/06** (2006.01)

(52) **U.S. Cl.**  
CPC ..... **E04H 4/06** (2013.01)

(58) **Field of Classification Search**  
CPC ..... E04H 4/1236  
USPC ..... 4/498-513; 482/55  
See application file for complete search history.

(56) **References Cited**

**U.S. PATENT DOCUMENTS**

3,748,810 A \* 7/1973 Mattingly ..... 52/741.12  
4,969,874 A \* 11/1990 Michel et al. .... 604/140

5,382,752 A \* 1/1995 Reyhan et al. .... 174/50  
5,752,860 A \* 5/1998 Greaves ..... 439/781  
6,684,588 B1 \* 2/2004 Jones ..... 52/298  
6,733,345 B2 5/2004 Weise  
7,269,861 B1 \* 9/2007 Miller ..... 4/609  
7,655,116 B1 \* 2/2010 Tilsner ..... 204/196.15  
7,732,707 B2 \* 6/2010 Kim ..... 174/7  
8,152,538 B1 \* 4/2012 Papageorge ..... 439/100  
2004/0009713 A1 \* 1/2004 Weise et al. .... 439/721  
2005/0091736 A1 \* 5/2005 Smith ..... 4/502  
2008/0216877 A1 \* 9/2008 Lawson ..... 134/111  
2011/0265420 A1 11/2011 Saviano  
2012/0314333 A1 \* 12/2012 Takeda et al. .... 361/230

\* cited by examiner

*Primary Examiner* — Lori Baker

(74) *Attorney, Agent, or Firm* — Leyendecker & Lemire, LLC

(57) **ABSTRACT**

A water bonding device for electrically grounding a swimming pool is described. Embodiments include a bonding electrode installed in a pool skimmer or pump strainer. The bonding electrode typically resides in a skimmer or strainer cavity, and a ground conductor coupled directly to the electrode extends out of the skimmer or strainer through a port. A plug assembly forms a water tight seal against the port and the ground conductor, providing a water tight access point for the ground conductor to enter the pool skimmer or pump strainer. The ground conductor is typically electrically connected to both the bonding electrode and a ground pole residing at ground potential.

**20 Claims, 8 Drawing Sheets**

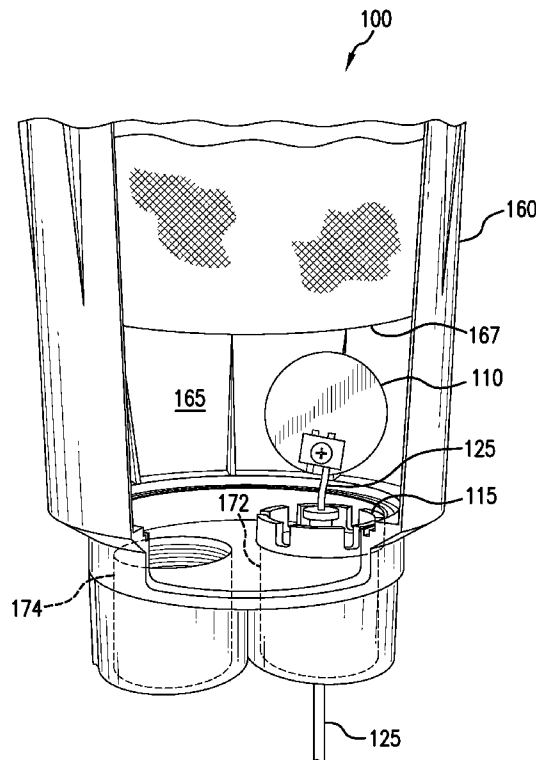

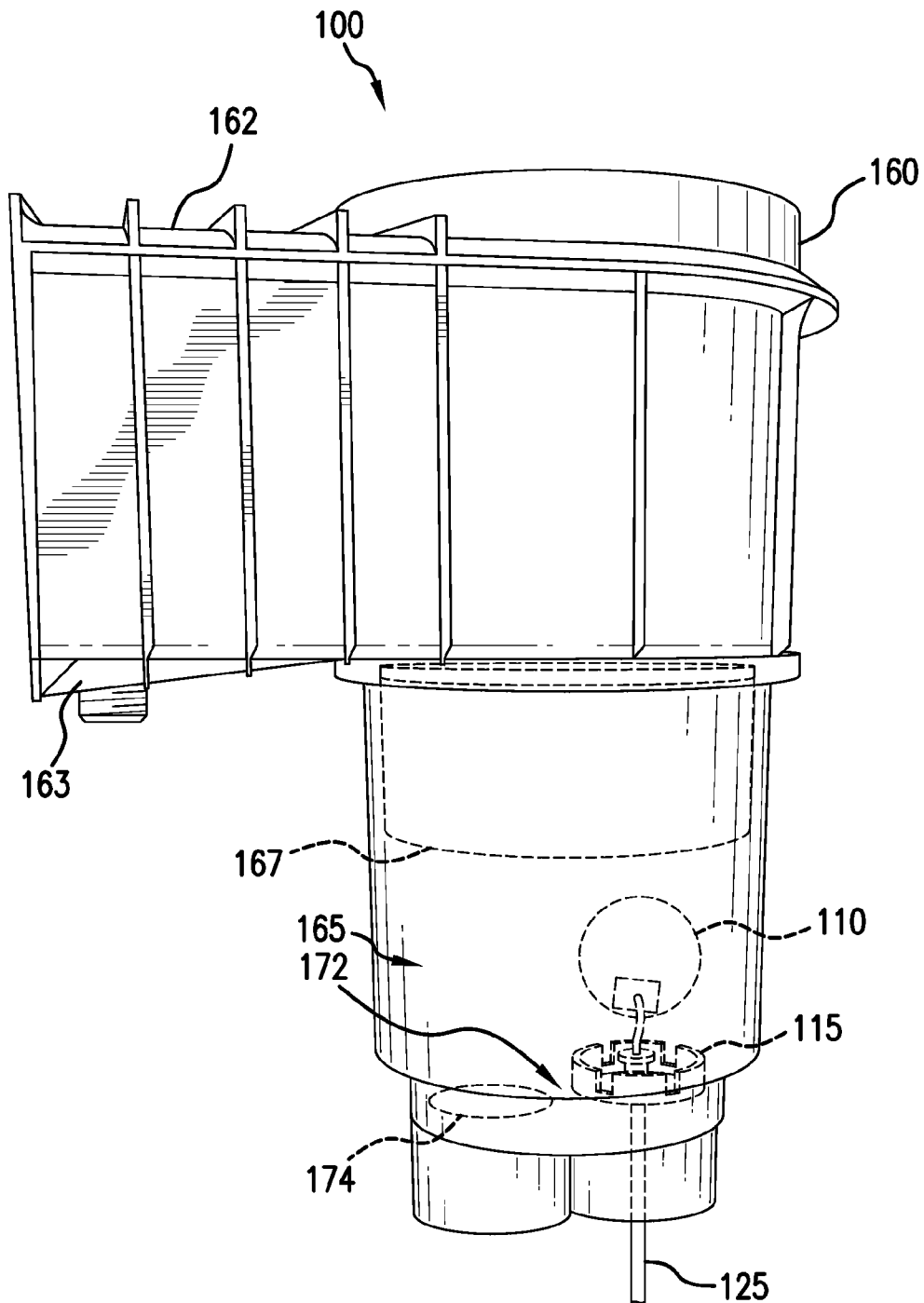

FIG. 1

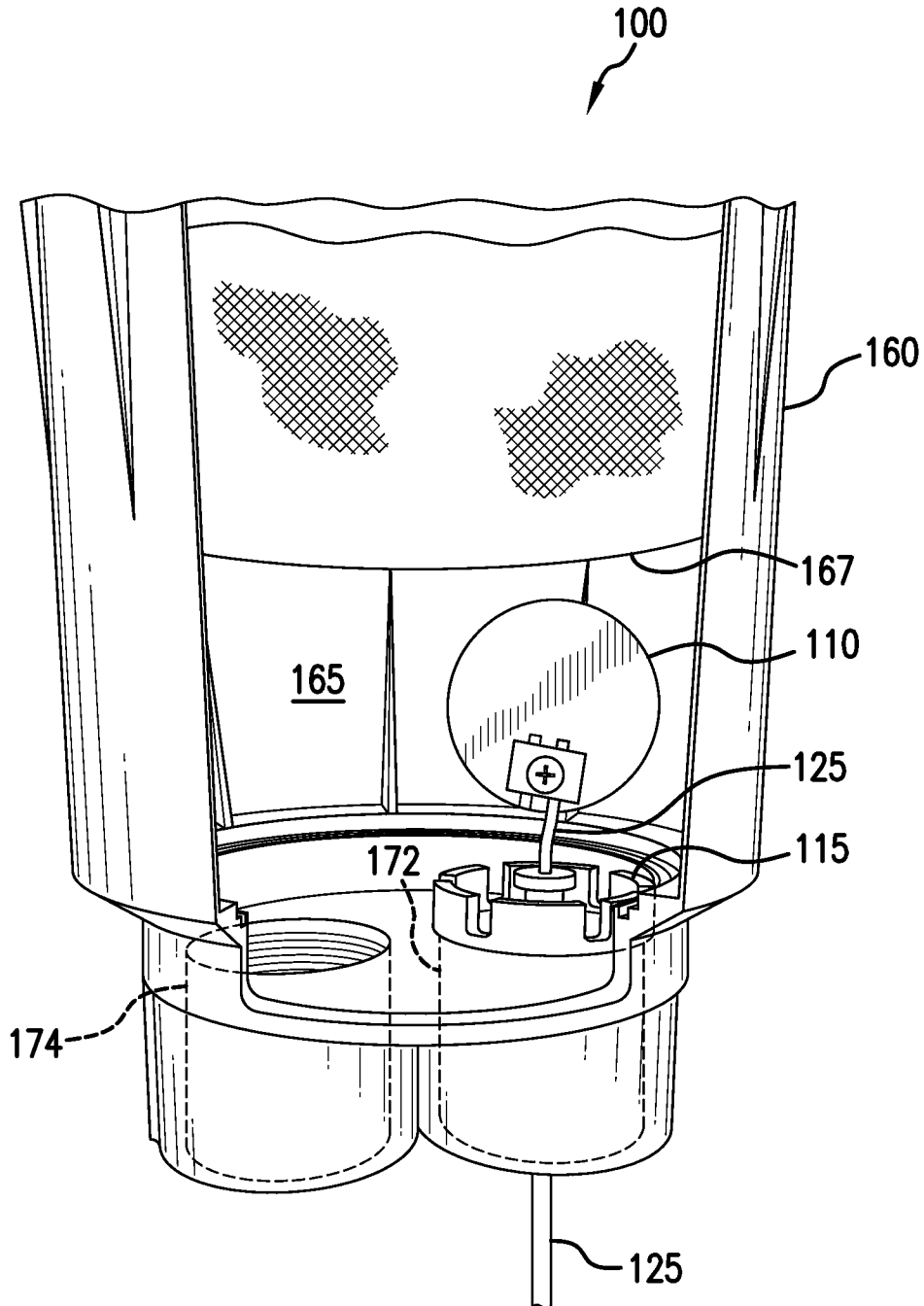

FIG. 2

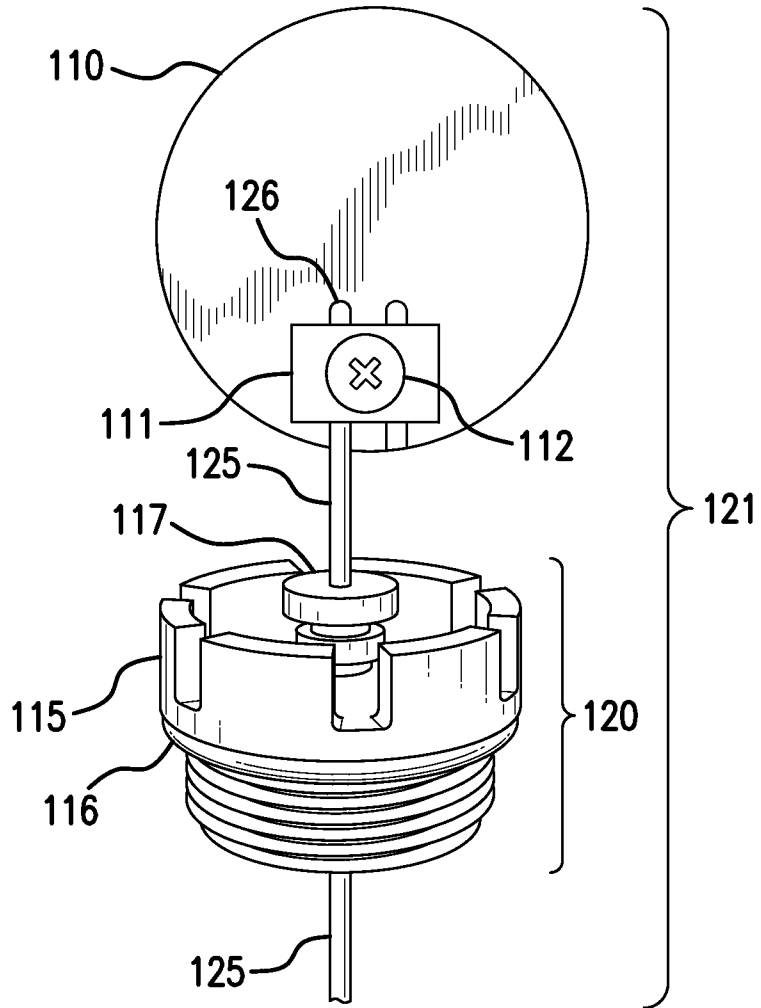

FIG. 3

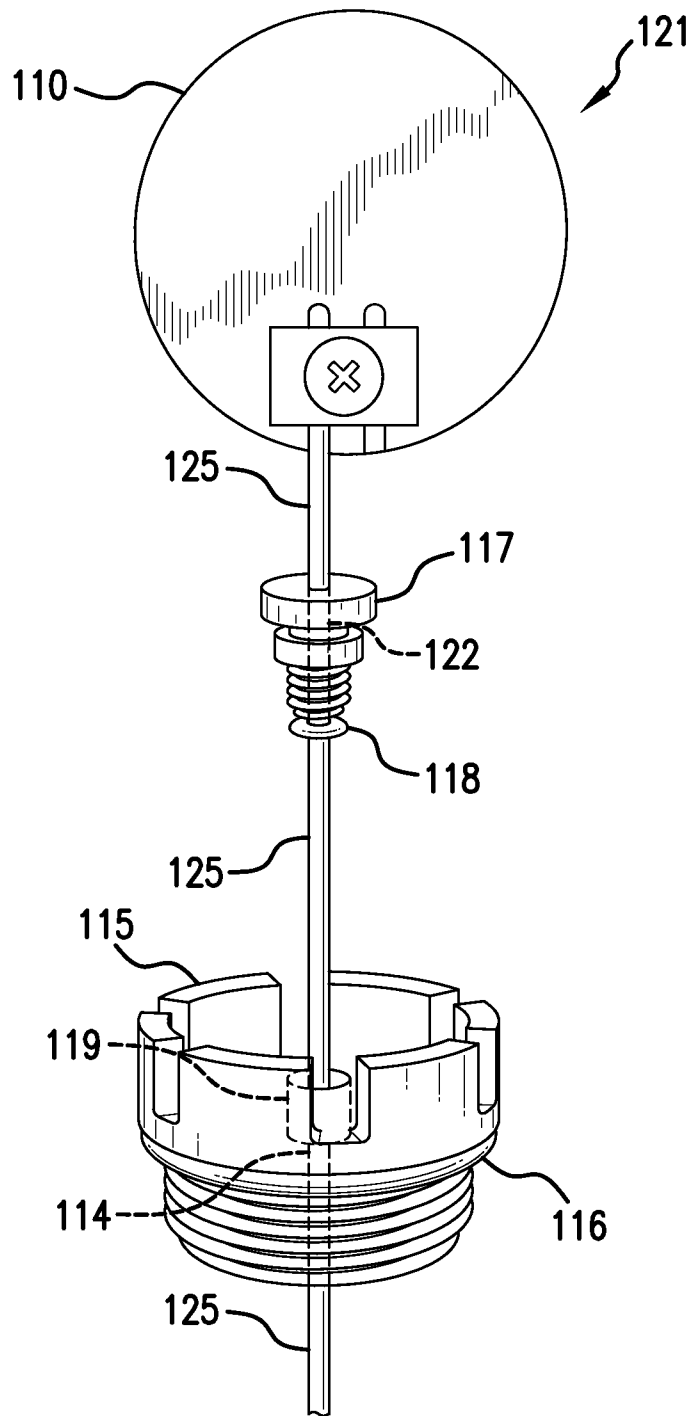

FIG. 4

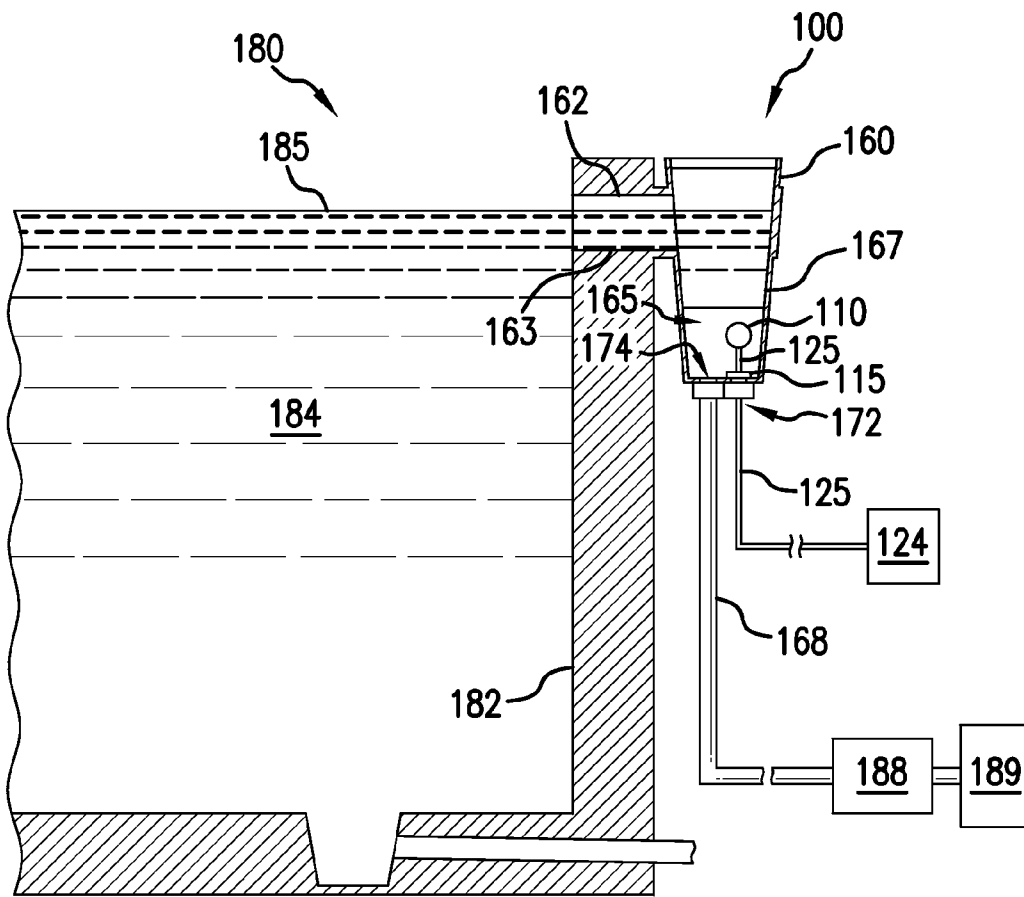

FIG. 5

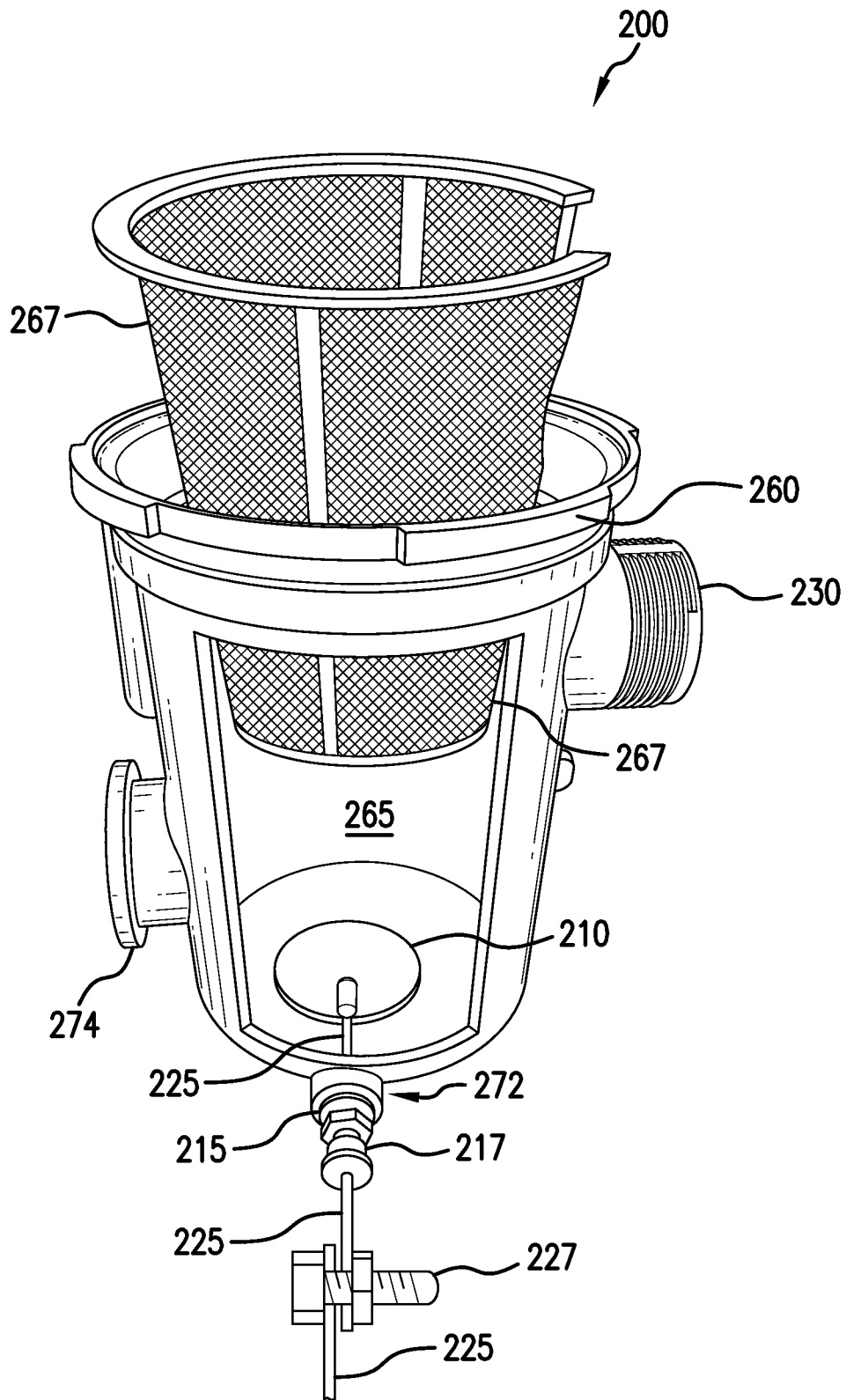

FIG. 6

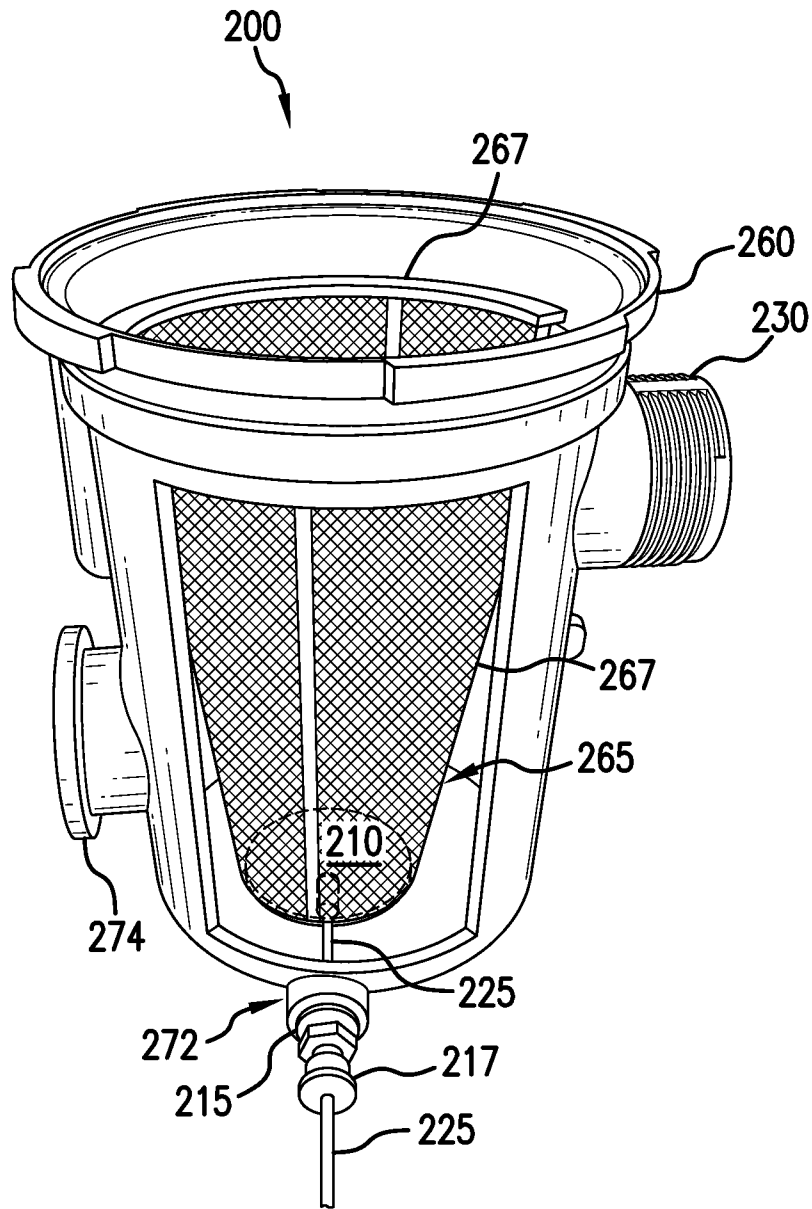

FIG. 7



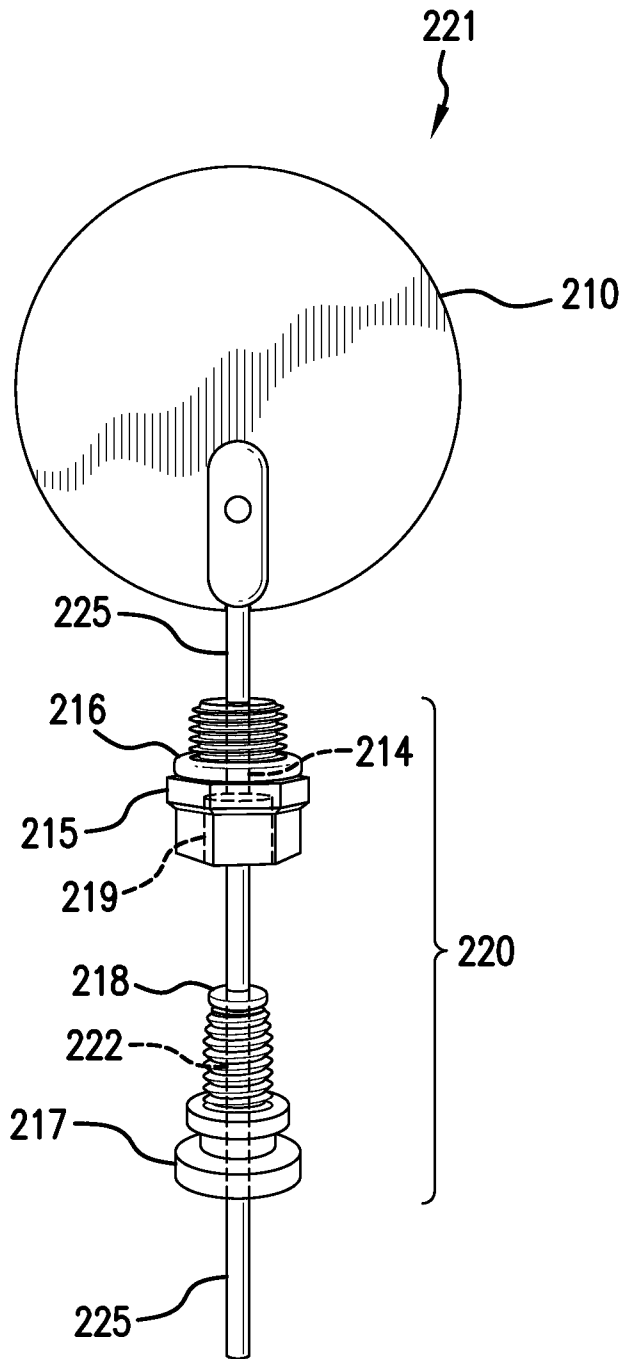

FIG. 8

## WATER BONDING DEVICE AND METHODS OF USE

### BACKGROUND

The 2008 National Electrical Code (NEC) requires that swimming pool water be electrically bonded in order to place the water at the same electrical potential as ground. Conductivity between the water and ground must be maintained by a solid copper conductor not smaller than #8 AWG. Bonding is also required for various other pool components in order to reduce voltage gradients between and among the pool water and the various components.

At least 9 square inches of bonding electrode surface area must be in contact with the water according to the NEC. However, stray voltage in the ground can create a slight voltage gradient wherein the ground is at higher potential than the pool water. Under such circumstances, the bonding electrode can slowly dissolve into the water through electrolysis, and insufficient bonding electrode surface area can result.

Finding or creating a port of entry for the grounding conductor presents a challenge for pool bonding, as does placing the bonding electrode at a location where it remains in contact with the pool water under varying conditions, such as where the water level drops, during pump failure or malfunction, or where water in pool filtration and recirculation plumbing becomes displaced by air.

Accordingly, an advantageously located replaceable bonding electrode that utilizes an existing port of entry for the ground conductor is needed.

### BRIEF DESCRIPTION OF THE DRAWINGS

FIG. 1 is a side, perspective view of a water bonding device according to an embodiment of the present invention.

FIG. 2 is a side, perspective, cut-away view of a water bonding device according to an embodiment of the present invention.

FIG. 3 is a perspective view of an electrode assembly according to an embodiment of the present invention.

FIG. 4 is a perspective view of an electrode assembly according to an embodiment of the present invention.

FIG. 5 is a side cross-section view of a water bonding device installed in a swimming pool, according to an embodiment of the present invention.

FIG. 6 is a perspective, cut-away view of a water bonding device according to an embodiment of the present invention.

FIG. 7 is a perspective, cut-away view of a water bonding device according to an embodiment of the present invention.

FIG. 8 is a perspective view of an electrode assembly according to an embodiment of the present invention.

### DETAILED DESCRIPTION

Embodiments of a water bonding device according to the present invention include a bonding electrode installed in filter inlet component. The filter inlet component is typically a pool skimmer or pump strainer. The pool skimmer version is typically used with built-in swimming pools, and the pump strainer version with above-ground pools.

The water bonding device typically includes a bonding electrode residing in a skimmer or strainer cavity and a ground conductor coupled directly to the electrode and extending out of the skimmer or strainer through a port. A plug assembly forms a water tight seal against the port and the ground conductor, providing a water tight access point for the ground conductor to enter the filter inlet component. The

ground conductor is typically electrically coupled to both the bonding electrode and a ground pole residing at ground potential.

The bonding electrode typically has a surface area greater than 9.0 square inches, which is the minimum surface area required for bonding a swimming pool. In typical use, the filter inlet component includes a cavity filled with water, within which the bonding electrode is submerged in water. The water in the cavity is typically in liquid communication with the water in the swimming pool. Accordingly, the bonding electrode is configured to bond pool water and all components electrically connected thereto. The water bonding electrode is easily installed, uninstalled, and replaced, in case the electrode dissolves, degrades, or otherwise becomes unsuitable for its desired purpose.

### TERMINOLOGY

The terms and phrases as indicated in quotation marks (“”) in this section are intended to have the meaning ascribed to them in this Terminology section applied to them throughout this document, including in the claims, unless clearly indicated otherwise in context. Further, as applicable, the stated definitions are to apply, regardless of the word or phrase’s case, to the singular and plural variations of the defined word or phrase.

The term “or” as used in this specification and the appended claims is not meant to be exclusive; rather the term is inclusive, meaning either or both.

References in the specification to “one embodiment”, “an embodiment”, “another embodiment”, “a preferred embodiment”, “an alternative embodiment”, “one variation”, “a variation” and similar phrases mean that a particular feature, structure, or characteristic described in connection with the embodiment or variation, is included in at least an embodiment or variation of the invention. The phrase “in one embodiment”, “in one variation” or similar phrases, as used in various places in the specification, are not necessarily meant to refer to the same embodiment or the same variation.

The term “couple” or “coupled” as used in this specification and appended claims refers to an indirect or direct physical connection between the identified elements, components, or objects. Often the manner of the coupling will be related specifically to the manner in which the two coupled elements interact.

The term “directly coupled” or “coupled directly,” as used in this specification and appended claims, refers to a physical connection between identified elements, components, or objects, in which no other element, component, or object resides between those identified as being directly coupled.

The term “approximately,” as used in this specification and appended claims, refers to plus or minus 10% of the value given.

The term “about,” as used in this specification and appended claims, refers to plus or minus 20% of the value given.

The terms “generally” and “substantially,” as used in this specification and appended claims, mean mostly, or for the most part.

The term “pool,” as used in this specification and appended claims, refers to swimming pools, hot tubs, spas, and similar structures where persons are intentionally in contact with reservoirs of water or wet surfaces surrounding the reservoirs. The contact can include being fully or partially submerged in the water.

The terms “removable”, “removably coupled”, “removably installed,” “readily removable”, “readily detachable”,

“detachably coupled”, “separable,” “separably coupled,” and similar terms, as used in this specification and appended claims, refer to structures that can be uncoupled, detached, uninstalled, or removed from an adjoining structure with relative ease (i.e., non-destructively, and without a complicated or time-consuming process), and that can also be readily reinstalled, reattached, or coupled to the previously adjoining structure.

Directional or relational terms such as “top,” “bottom,” “front,” “back,” “above,” “beneath,” and “below,” as used in this specification and appended claims, refer to relative positions of identified elements, components, or objects, where the components or objects are oriented in an upright position as normally installed or used.

#### A First Embodiment Water Bonding Device

A first embodiment water bonding device **100** is illustrated in FIGS. 1-5. The first embodiment water bonding device comprises a filter inlet component **160** including a main cavity **165**, and a bonding electrode **110** residing within the main cavity **165**. The filter inlet component **160** of the first embodiment is a pool skimmer familiar to persons skilled in the art. The pool skimmer is shown in FIG. 5 installed in a swimming pool **180** built into the ground. The pool skimmer includes a skimmer basket **167** for filtering water that flows through the main cavity **165**. The filter inlet component **160** further comprises a first port **172** and a second port **174**.

The first embodiment water bonding device **100** further comprises a plug **115** threaded into the first port **172**, and thus removably installed therein. The water bonding device **100** further includes a ground conductor **125** directly and removably coupled to the bonding electrode **110** by use of a clamp **111** that pinches the ground conductor **125** proximate its first end **126** between the clamp **111** and the bonding electrode **110**. The bonding electrode **110** is electrically connected to the ground conductor **125** in addition to being removably coupled thereto. A clamp screw **112** threads into the bonding electrode **110** and thus presses the clamp **111** against the ground conductor **125** and the bonding electrode **110**, holding the ground conductor **125** fast therebetween.

The ground conductor **125** is typically, but not necessarily, a #8 AWG solid copper wire. Variations include a ground conductor comprising other electrically conducting material. In some embodiments, the ground conductor **125** is bent where it enters the skimmer cavity **165**, such that the bonding electrode **110** lies relatively flat against a bottom of the cavity **165**. This configuration enables the electrode to fit beneath the skimmer basket **167** even where space beneath the skimmer basket is minimal.

The bonding electrode **110** is readily removable from the ground conductor **125** by loosening the clamp screw **112**, which allows the ground conductor first end **126** to slide from between the clamp **111** and electrode **110**. The same bonding electrode **110** or a replacement bonding electrode can be subsequently affixed to the ground conductor **125** in the same manner as described above, with a portion of the ground conductor **125** proximate the first end **126** being held fast between the clamp **111** and the electrode **110**. The removable and replaceable character of the bonding electrode **110** is beneficial in circumstances where a ground potential causes the bonding electrode to dissolve or otherwise disintegrate over time, and therefore have insufficient surface area (<9.0 square inches) for adequate water bonding. The removable bonding electrode **110** can also simplify installation because it allows the ground conductor first end **126** to be inserted through the plug bore **114** and fitting bore **122**.

The bonding electrode **110** typically comprises a circular disk having a diameter of approximately 2.5 inches, and thus

having a surface area of approximately 4.9 square inches for each of the front and back sides of the electrode **110**. The bonding electrode **110** is typically approximately 0.125 inch thick, resulting in a circumferential edge having a surface area of approximately 0.98 square inch.

As best seen in FIGS. 3 and 4, the first embodiment water bonding device further comprises a conductor fitting **117** and a fitting gasket **118**, both of which are configured to encircle the ground conductor **125**. The conductor fitting **117** is typically a nylon thumb screw including a central bore **122**. The thumb screw typically removably installs in a fitting receptacle **119**. The conductor fitting **117** is typically, but not necessarily, threaded, and thus can engage in the fitting receptacle **119** via complementary threads typically residing in the fitting receptacle, resulting in a threaded coupling between the fitting receptacle and the conductor fitting. In some embodiments, the conductor fitting engages the fitting receptacle by a friction fit, twist-lock mechanism, or by other means. A plug bore **114** extends through the center of the plug **115** from a bottom of the fitting receptacle **119**.

The conductor fitting **117** includes a fitting bore **122** through a center of the conductor fitting **117**, and through which the ground conductor **125** extends through the conductor fitting. The fitting gasket **118** typically resides in the fitting receptacle **119** at a bottom of the conductor fitting **117**. When the conductor fitting **117** is installed in the fitting receptacle **119**, the fitting gasket **118** resides within the receptacle **117** and can form a water tight seal around the ground conductor **125**. The fitting gasket **118** can also seat against a bottom of the fitting receptacle **119** to form a water tight seal between the conductor fitting **117** and fitting receptacle **119**. Where the fitting gasket **118** is compressed between the conductor fitting and fitting receptacle, for instance where the conductor fitting threads tightly into the fitting receptacle, a watertight seal is more readily formed by the gasket **118**.

The fitting gasket **118** of the first embodiment water bonding device **100** typically, but not necessarily, comprises an elastomeric O-ring familiar to persons skilled in art. Embodiments of fitting gaskets include, but are not limited to, compression fittings, ferrules, seals, gaskets, and the like.

The first embodiment water bonding device **100** further comprises a plug gasket **116** adapted to form a water tight seal between the plug **115** and the filter inlet component **160** when the plug threads into or is otherwise installed in the first port **172**. The plug gasket seals against the plug **115** and filter inlet component **160** when compressed therebetween. The plug gasket **116** of the first embodiment water bonding device **100** typically, but not necessarily, comprises an elastomeric O-ring familiar to persons skilled in art. Variations of plug gaskets include, but are not limited to, compression fittings, ferrules, seals, gaskets, and the like.

The plug **115** and conductor fitting **117** can be referred to collectively as a plug assembly **120**. The plug **115**, conductor fitting **117**, and bonding electrode **110** can be referred to as an electrode assembly **121**. In some embodiments, the plug assembly or the electrode assembly can include the fitting gasket **118** and the plug gasket **116**. The electrode assembly **121** typically resides beneath a skimmer basket **167** when the assembly **121** is installed in the pool skimmer **160**.

In FIG. 5, the first embodiment water bonding device **100** is shown installed in a swimming pool **180**. The swimming pool **180** is a built-in pool. The bonding electrode **110** resides below a pool water surface **185**. The pool water **184** extends into the pool inlet filter assembly **160** through a skimmer inlet **162**, which extends through a pool wall **182**. The bonding electrode **110** typically remains submerged, and thus continues to maintain the pool water at approximately ground

potential, so long as the pool water surface **185** remains above a skimmer inlet bottom **163**. A pool water conduit **168** typically extends from the second port **174** of the filter inlet component **160** for delivery of water from the first embodiment filter inlet component **160** to a water filtration system **188** and water pump **189**.

The ground conductor **125** extends from the bonding electrode **110** through the first port **172** to a ground pole **124**. The ground pole **124** can be a grounded object such as, but not limited to, a grounded terminal on a service panel, a metal water pipe that extends into the ground, a metal stake or other metal object installed in the ground and having substantial electrical connectivity therewith, or other electrically conducting object electrically connected to the ground. As illustrated in FIG. 5, water inside the swimming pool is maintained at ground electrical potential.

#### A Second Embodiment Water Bonding Device

A second embodiment water bonding device **200** is illustrated in FIGS. 6-8. The second embodiment water bonding device comprises a filter inlet component **260** including a main cavity **265**, and a bonding electrode **210** residing within the main cavity **265**. The filter inlet component **260** of the second embodiment is a pump strainer familiar to persons skilled in the art. The pump strainer is typically installed in an above-ground swimming pool. The pump strainer includes a strainer basket **267** for straining water that flows through the main cavity **265**. The filter inlet component **260** further comprises an inlet port **230**, a drain port **272**, and an outlet port. The drain port **272** of the second embodiment is analogous to the first port **172** of the first embodiment water bonding device **100**. Accordingly, the drain port of a pump strainer can be referred to as a first port.

The second embodiment water bonding device **200** further comprises a plug **215** threaded into the drain port **272**, and thus removably installed therein. The water bonding device **200** further includes a ground conductor **225** directly coupled to the bonding electrode **210**. The ground conductor **225** can be referred to as an electrical conductor or a wire.

The water bonding electrode **210** typically comprises a circular disk having a diameter of approximately 2.5 inches, and thus having a surface area of approximately 4.9 square inches for each of the front and back sides of the electrode **210**. The ground conductor **225** is typically a #8 AWG solid copper wire. As best seen in FIG. 6, the ground conductor **225** can include separable sections spliced by use of a connector **227**. The connector **227** of the second embodiment is typically a split bolt connector.

The second embodiment water bonding device further comprises conductor fitting **217** and a fitting gasket **218**, both of which are configured to encircle the ground conductor **225**. The conductor fitting **217** is typically a nylon thumb screw that removably installs in a fitting receptacle **219**, the fitting receptacle **219** being a recess in the plug **215** configured to receive the conductor fitting **217**. The conductor fitting **217** typically engages the fitting receptacle **219** via complementary threads residing in the receptacle, resulting in a threaded coupling between the fitting receptacle **219** and the conductor fitting **217**. The plug **215** further includes a plug bore **214** (shown in hidden line) that passes through a center of the plug **215**.

The conductor fitting **217** includes a fitting bore **222** (shown in hidden line) through a center of the conductor fitting **217**, and through which the ground conductor **225** extends. The fitting gasket **218** (see FIG. 8) typically seals against an inside surface of the fitting receptacle. When the conductor fitting **217** is installed in the fitting receptacle **219**, the fitting gasket **218** resides within the receptacle **217** and

can form a water tight seal around the ground conductor **225**. The fitting gasket **218** can furthermore seat against a bottom inside surface of the fitting receptacle **219** to form a water tight seal with the plug **215**. The fitting gasket **218** of the second embodiment water bonding device **200** typically comprises an elastomeric O-ring.

The plug **215** and conductor fitting **217** can be referred to collectively as a plug assembly **220**. The plug **215**, conductor fitting **217**, and bonding electrode **210** can be referred to as an electrode assembly **221**. In some embodiments, the plug assembly or the electrode assembly can include the fitting gasket **218** and the plug gasket **216**. The electrode assembly **221** typically resides outside a strainer basket **267** when the assembly **221** is installed in the pump strainer **260**.

The connector **227** that splices the ground conductor **225** of the second embodiment typically resides outside the pump strainer **260** when the electrode assembly **221** is installed in the pump strainer **260**. The connector resides a distance from the drain port **272** that is preferably less than 12 inches, more preferably less than 6 inches, and most preferably less than 4 inches. As shown in FIG. 6, the connector **227** resides about 3 inches from the drain port **272**.

#### A Method of Using a Water Bonding Device

A method of using a first embodiment water bonding device **100** includes installing the water bonding device as follows in a built-in swimming pool. The swimming pool typically, but not necessarily, has been previously constructed or installed, and the installation thus includes retrofitting a pre-existing built-in pool. The pre-existing swimming pool includes a pool skimmer **160**, which, in combination with the first embodiment water bonding device, provides a convenient port of entry for a ground conductor. The pool skimmer also provides a protected space (the skimmer main cavity **165**) within which the bonding electrode **110** can be readily installed. With the bonding electrode installed beneath the skimmer basket **167** at a bottom of the main cavity **165**, the electrode is readily accessible, yet is configured to remain under water even where the water drops to a relatively low level.

A first operation of installing the water bonding device includes installing a plug **115** in a first port **172** disposed at a bottom of the pool skimmer **160**. The first port **172** is typically one of two ports molded, formed, or otherwise installed in the pool skimmer when the skimmer is manufactured. The plug **115** typically, but not necessarily, includes male threads that engage a complementary set of female threads in the first port **172**. The plug forms a water tight seal with the first port, the water tight seal being facilitated by the plug gasket **116**. The plug further includes a plug bore **114** that passes through a center of the plug.

A second operation of installing the first embodiment water bonding device includes passing the ground conductor **125** into the skimmer main cavity **165** through the plug bore **114**. The second operation is typically, but not necessarily, performed after the first operation, in which case the ground conductor **125** traverses the first port **172** as the conductor passes through the plug bore **114**. However, in some methods of use the ground conductor is brought into the main cavity first through the first port, and is subsequently passed through the plug bore **114**, in which case the plug **115** is installed in the first port with a portion of the ground conductor already residing in the plug bore **114** and fitting receptacle **119**.

A third operation of installing the first embodiment water bonding device includes passing the ground conductor **125** through the fitting gasket **118** and fitting bore **122** of the

conductor fitting **117**. The first three operations are interchangeable with respect to the order in which they are performed.

A fourth operation of installing the first embodiment water bonding device includes installing the conductor fitting **117** snugly in the fitting receptacle **119**, so the conductor fitting **117** forms a water tight seal between the plug **115** and the ground conductor **125**. The water tight seal is facilitated by the action of the fitting gasket **118** forming a water tight seal around the ground conductor **125**, and also against the fitting receptacle. Accordingly, the first embodiment plug assembly **120**, comprising the plug **115**, plug gasket **116**, conductor fitting **117**, and fitting gasket **118**, creates a water tight port of entry through which the ground conductor **125** enters the pool skimmer **160** by exploiting the pre-existing first port **172** in the skimmer.

A fifth operation of installing the first embodiment water bonding device includes installing the bonding electrode **110** on the ground conductor **125**, thus creating a direct electrical connection between the bonding electrode and the ground conductor.

A sixth operation of installing the first embodiment water bonding device includes installing the skimmer basket **167** in the skimmer. Consequently, the bonding electrode **110** resides in the skimmer main cavity **165** beneath the skimmer basket. The first through sixth operations of installing the first embodiment water bonding device are typically, but not necessarily, performed in the order listed here.

The method of using the first embodiment water bonding device further comprises submerging the bonding electrode **110** in pool water residing in the pool skimmer main cavity **165**. The pool water in the main cavity is typically in liquid communication with pool water residing throughout the swimming pool and associated plumbing.

The method of using the first embodiment water bonding device further includes removing the bonding electrode **110** and replacing it with another bonding electrode.

#### ALTERNATIVE EMBODIMENTS AND VARIATIONS

The various embodiments and variations thereof, illustrated in the accompanying Figures and/or described above, are merely exemplary and are not meant to limit the scope of the invention. It is to be appreciated that numerous other variations of the invention have been contemplated, as would be obvious to one of ordinary skill in the art, given the benefit of this disclosure. All variations of the invention that read upon appended claims are intended and contemplated to be within the scope of the invention.

In an alternative embodiment, the second embodiment plug assembly **220** (see FIG. **8**) is used as a water tight seal for bringing an electrical conductor into a tank or vessel through a port of entry in the tank. The port of entry is typically, but not necessarily, a threaded port such as a drain, tank inlet, or tank outlet. The plug **215** and plug gasket **216** together form a watertight seal with the port of entry. The conductor fitting **217** and fitting gasket **218** form watertight seals with the plug **215** and with the electrical conductor **225**. In some embodiments, the electrical conductor links a bonding electrode inside the tank or vessel to a ground pole outside the tank. Embodiments include an electrical conductor that links a pH electrode or other sensor inside the tank to an electrical instrument. Variations include an electrical cord for operating a submersible pump within the tank or vessel, or a thermocouple wire for determining temperature in the tank.

I claim:

1. A water bonding device comprising:
  - a filter inlet component selected from the group consisting of a pool skimmer and a pump strainer, the filter inlet component including a main cavity and a first port disposed proximate a bottom of the main cavity;
  - a plug assembly removably installed in the first port, the plug assembly including a plug penetrated by a plug bore, the plug forming a water tight seal with the first port; and
  - a bonding electrode (i) comprising a metal structure having a surface area of at least 9.0 square inches, (ii) residing within the main cavity, and (iii) being directly coupled to a ground conductor, the ground conductor extending from within the main cavity through the plug bore to outside the filter inlet component.
2. The device of claim 1, wherein the plug assembly forms a water tight seal around the ground conductor.
3. The device of claim 2, wherein the plug assembly further comprises a conductor fitting removably installed in the plug, the conductor fitting being penetrated by a fitting bore and the ground conductor extending through the fitting bore.
4. The device of claim 3, wherein:
  - the plug further comprises a fitting receptacle within which the plug fitting is installed; and
  - the plug assembly further comprises a fitting gasket residing within the fitting receptacle and forming a seal around the ground conductor.
5. The device of claim 4, wherein the ground conductor comprises a solid copper wire not smaller than 8 AWG.
6. The device of claim 5, wherein the filter inlet component is a pool skimmer and the bonding electrode is removably coupled to the ground conductor.
7. A water bonding system comprising:
  - a built-in swimming pool comprising a pool wall;
  - the water bonding device of claim 6, wherein the pool skimmer further includes:
    - a skimmer inlet projecting through the pool wall;
    - a second port directly coupled to a pool water conduit, the pool water conduit providing fluid communication between the pool skimmer and a pool filter.
8. The water bonding device of claim 5, wherein the pool filter inlet component is a pump strainer and the first port is a drain port.
9. The water bonding device of claim 8, wherein the ground conductor is spliced with a connector, the connector residing outside the main cavity and within 12 inches of the drain port.
10. A water bonding device comprising:
  - a plug assembly including (i) a plug penetrated by a plug bore, and (ii) a fitting receptacle residing in the plug;
  - a conductor fitting configured to removably install in the fitting receptacle, the conductor fitting being penetrated by a fitting bore;
  - a bonding electrode comprising a metal structure having a surface area of at least 9.0 square inches, the bonding electrode being adapted to affix to a #8 AWG or larger solid copper conductor.
11. A method of using the water bonding device of claim 10 comprising:
  - providing a built-in swimming pool, the swimming pool including a pool skimmer having a main cavity and a first port;
  - passing a first end of a ground conductor from outside the pool skimmer through the first port, the plug bore, and the fitting bore;
  - installing the plug in the first port;
  - installing the fitting in the fitting receptacle;

9

installing the bonding electrode on the ground conductor proximate the first end, whereupon the bonding electrode resides within the main cavity.

12. The method of claim 11, wherein the plug assembly forms a water tight seal with the ground electrode and with pool skimmer. 5

13. The method of claim 12, wherein the ground conductor is directly coupled to a ground pole.

14. The method of claim 13, wherein the pool skimmer further comprises a second port directly coupled to a pool water conduit, the pool water conduit providing fluid communication between the pool skimmer and a pool filter. 10

15. The method of claim 14, further comprising at least partially filling the swimming pool with water, the water extending from the swimming pool into the cavity and submerging the bonding electrode. 15

16. The method of claim 15, wherein the swimming pool water and ground pole have approximately equal electric potential.

17. A water bonding device comprising:

a pool skimmer including:

an inlet;

a main cavity;

a first port disposed at a bottom of the main cavity;

10

a second port disposed at the bottom of the main cavity; and

a skimmer basket residing in the main cavity;

a plug assembly removably installed in the first port, the plug assembly including a plug penetrated by a plug bore, the plug forming a water tight seal with the first port; and

a bonding electrode (i) comprising a metal structure having a surface area of at least 9.0 square inches, (ii) residing within the main cavity beneath the skimmer basket, and (iii) being directly coupled to a ground conductor, the ground conductor extending from within the main cavity through the plug bore to outside the filter inlet component.

18. The water bonding device of claim 17, wherein the ground conductor is directly coupled to a ground pole.

19. The water bonding device of claim 18, wherein the second port is directly coupled to a pool water conduit, the pool water conduit providing fluid communication between the pool skimmer and a pool filter. 20

20. The water bonding device of claim 19, wherein the pool water conduit is directly coupled to the pool filter.

\* \* \* \* \*